



YJD150G10AJ

N-Channel Enhancement Mode Field Effect Transistor

Product Summary

V_{DS}	100V
I_D	6A
$R_{DS(ON)}$ (at $V_{GS}=10V$)	150m
$R_{DS(ON)}$ (at $V_{GS}=4.5V$)	185m
100% EAS Tested	
100% VDS Tested	

General Description

Split gate trench MOSFET technology
Excellent package for heat dissipation
High density cell design for low $R_{DS(ON)}$
Moisture Sensitivity Level 1
Epoxy Meets UL 94 V-0 Flammability Rating
Halogen Free

Applications

Power switching application
Uninterruptible power supply
DC-DC convertor

Absolute Maximum Ratings ($T_J=25$ unless otherwise noted)

Parameter	Symbol
-----------	--------



YJD150G10AJ

Electrical Characteristics ($T_J=25$ unless otherwise noted)

Parameter	Symbol	Conditions	Min	Typ	Max	Units
Static Parameter						
Drain-Source Breakdown Voltage	BV_{DSS}	$V_{GS}=0V, I_D=250\mu A$	100	-	-	V
Zero Gate Voltage Drain Current	I_{DSS}	$V_{DS}=100V, V_{GS}=0V$	-	-	1	A
		$V_{DS}=100V, V_{GS}=0V, T_J=150$	-	-	100	
Gate-Body Leakage Current	I_{GSS}	$V_{GS}=\pm 20V, V_{DS}=0V$	-	-	± 100	



Typical Electrical and Thermal Characteristics Diagrams

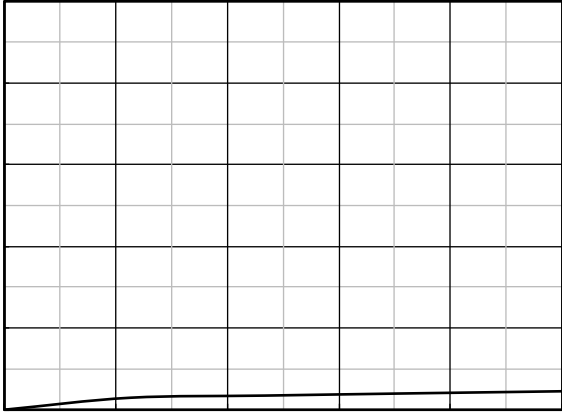

Figure 1. Output Characteristics

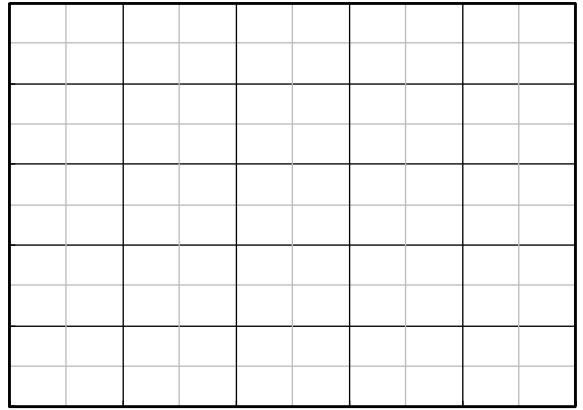

Figure 2. Transfer Characteristics

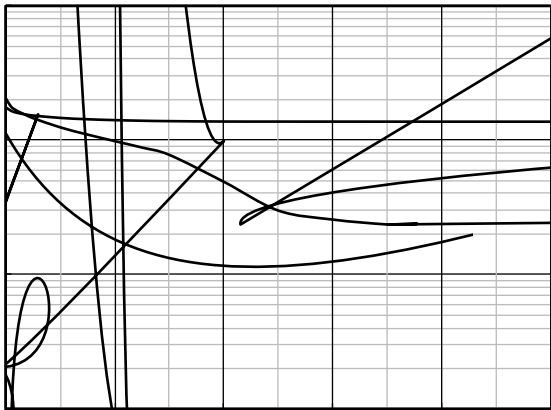

Figure 3. Capacitance Characteristics

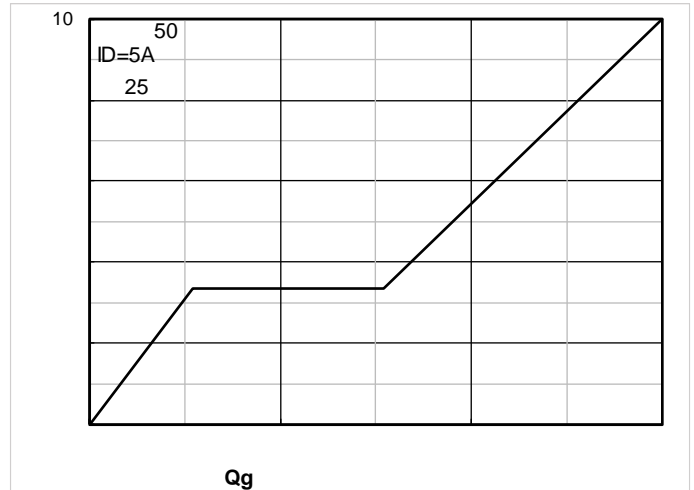

Figure 4. Gate Charge

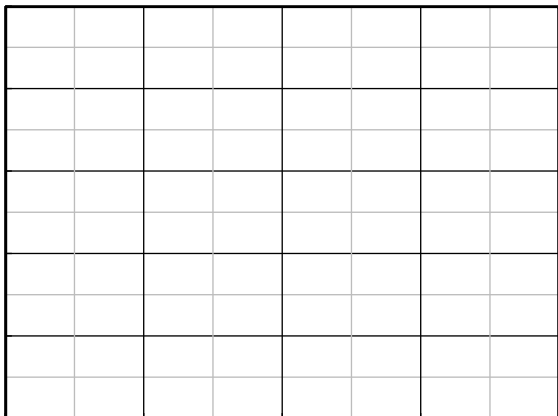

Figure 5. On-Resistance vs Gate to Source Voltage

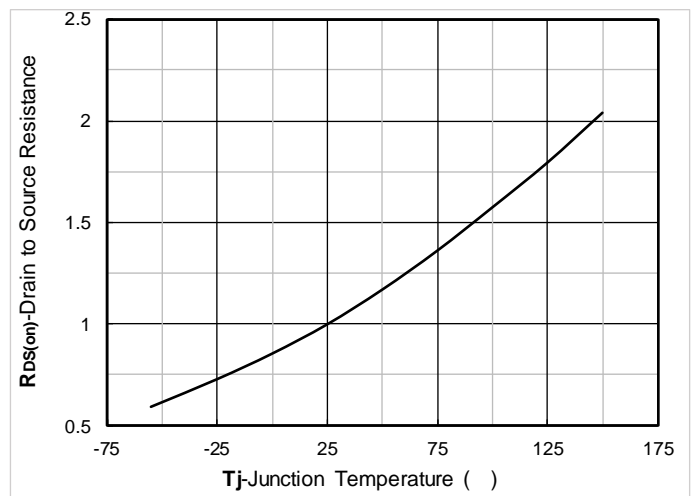

Figure 6. Normalized On-Resistance

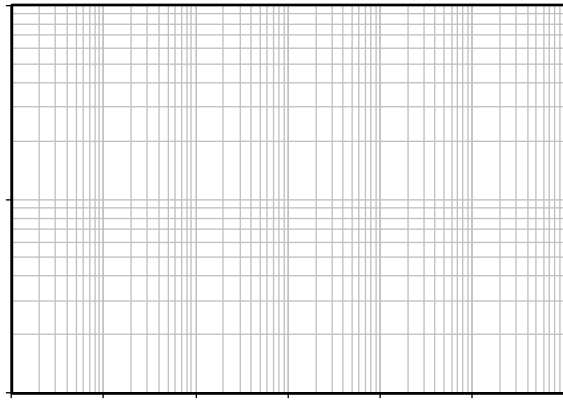

Figure 13. Maximum Transient Thermal Impedance

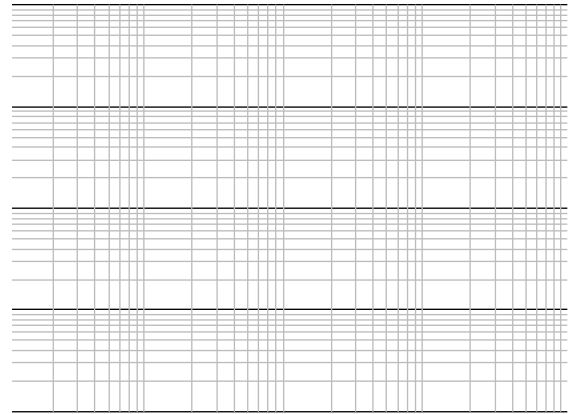

Figure 14. Safe Operation Area

Test Circuits & Waveforms

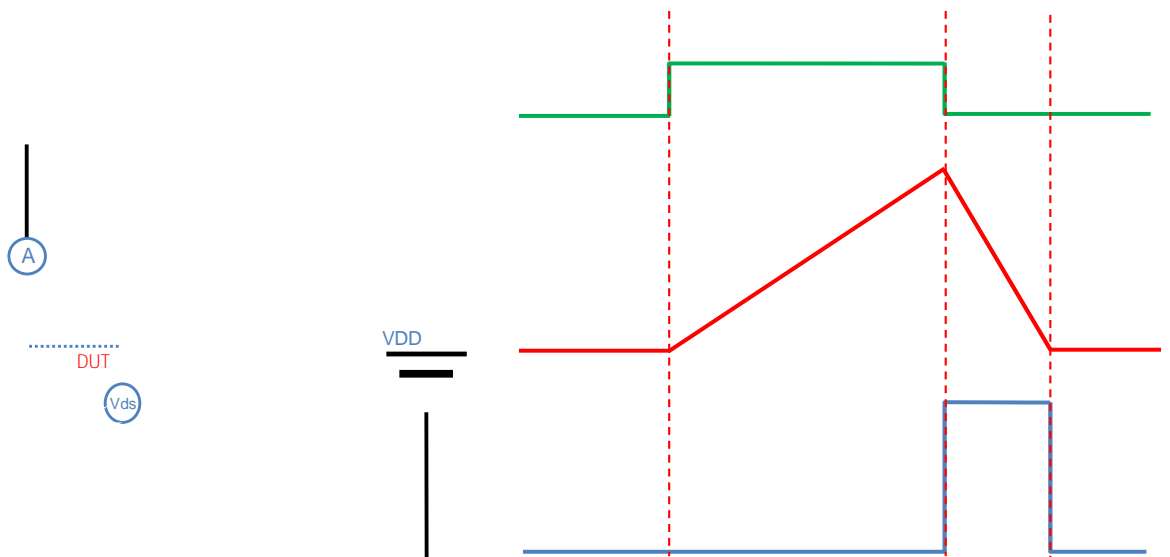

Figure A. Unclamped Inductive Switching (UIS) Test Circuit & Waveform



YJD150G10AJ

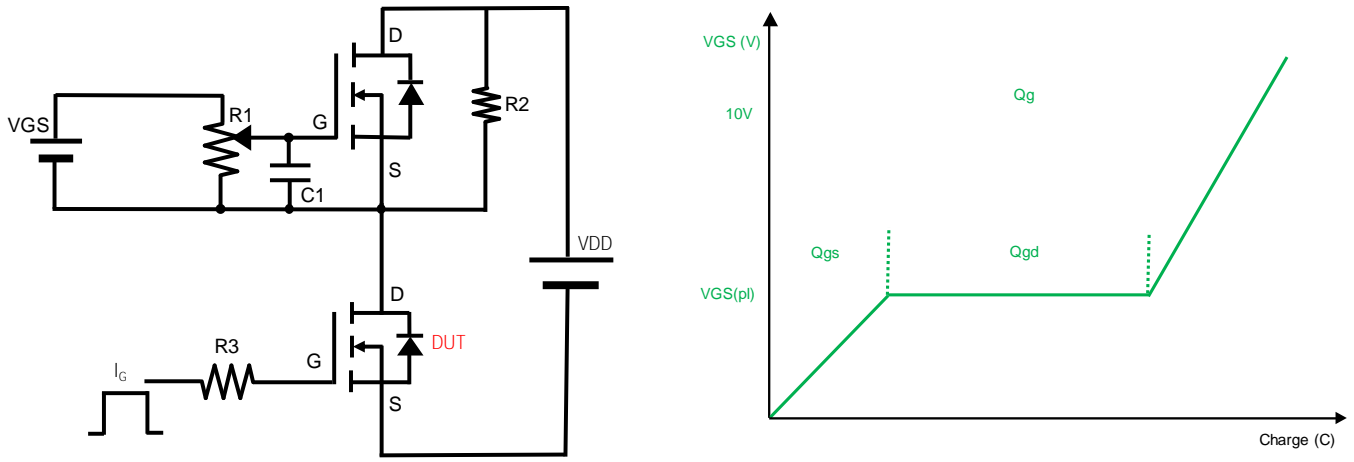
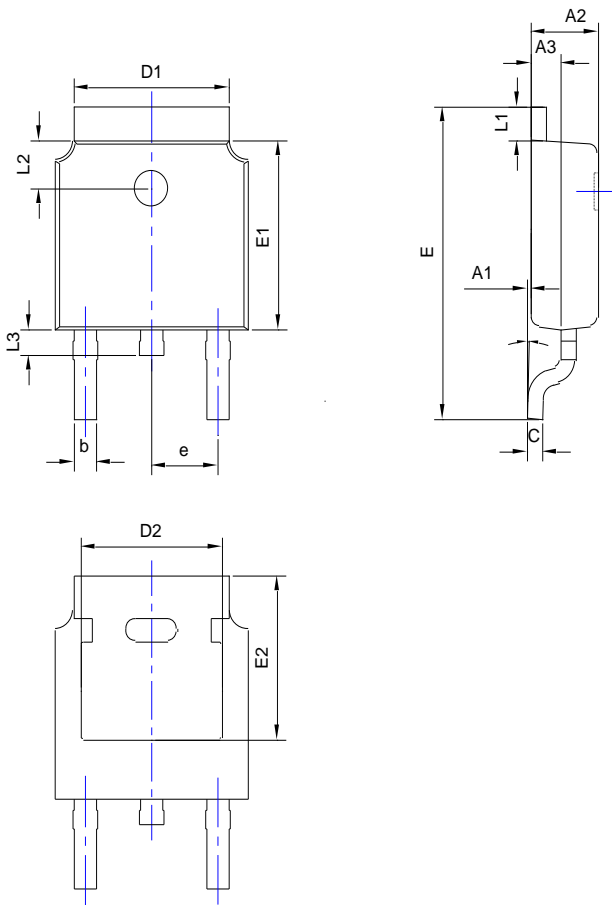

Figure B. Gate Charge Test Circuit & Waveform



YJD150G10AJ

TO-252-B Package information



SYMBOL	DIMENSIONS			
	INCHES			
	MIN.	NOM.		
A1	0.000			
A2	0.087	0.091		
A3	0.035	0.039		
b	0.026	0.030		
c	0.018	0.020		
D	0.256	0.260		
D1				
D2	0.181	0.189		
E	0.390	0.398		
E1	0.236	0.240		

NOTE:
1.PACKAGE BODY SIZES EXCLUDE MOLD FLASH AND GATE BURRS.
2.TOLERANCE 0.1mm UNLESS OTHERWISE SPECIFIED.
3.THE PAD LAYOUT IS FOR REFERENCE PURPOSES ONLY.



YJD150G10AJ

Disclaimer

The information presented in this document is for reference only. Yangzhou Yangjie Electronic Technology Co., Ltd. reserves the right to make changes without notice for the specification of the products displayed herein to improve reliability, function or design or otherwise.

The product listed herein is designed to be used with ordinary electronic equipment or devices, and not designed to be used with equipment or devices which require high level of reliability and the malfunction of which would directly endanger human life (such as medical instruments, transportation equipment, aerospace machinery, nuclear-reactor controllers, fuel controllers and other safety devices), Yangjie or anyone on its behalf, assumes no responsibility or liability for any damages resulting from such improper use of sale.

This publication supersedes & replaces all information previously supplied. For additional information, please contact us at (86)514-3511111 or (86)514-3511111.