

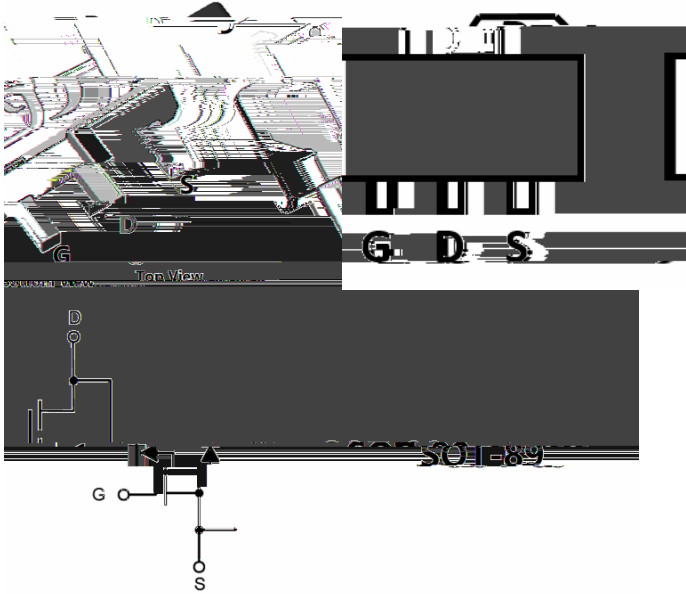

N-Channel Enhancement Mode Field Effect Transistor



Product Summary

V_{DS}	100V
I_D	3.0A
$R_{DS(ON)}$ (at $V_{GS}= 10V$)	110mohm
$R_{DS(ON)}$ (at $V_{GS}= 4.5V$)	120mohm

General Description

Trench Power MV MOSFET technology
 Excellent package for heat dissipation
 High density cell design for low $R_{DS(ON)}$
 Epoxy Meets UL 94 V-0 Flammability Rating
 Halogen Free

		V_{DS}	100	V
Gate-source Voltage		V_{GS}	± 20	V
Drain Current	$T_A=25$	I_D	3	A
	$T_A=70$		2.4	
Pulsed Drain Current ^A		I_{DM}	12	A
Total Power Dissipation	$T_A=25$	P_D	1.5	W
	$T_C=25$		4.0	W
Thermal Resistance Junction-to-Ambient ^B		R_{JA}	83	/ W
Thermal Resistance Junction-to-Case		R_{JC}	31	/ W Ordering Inform

PREFERRED P/N	PACKING CODE	Marking	MINIMUM PACKAGE(pcs)	INNER BOX QUANTITY(pcs)	OUTER CARTON QUANTITY(pcs)	DELIVERY MODE
YJH03N10A	F1	1003	1000	10000	40000	7" reel
	F2	1003	1000	8000	32000	7" reel



YJH03N10A

Electrical Characteristics ($T_J=25$ unless otherwise noted)

Parameter	Symbol	Conditions	Min
-----------	--------	------------	-----



Typical Performance Characteristics

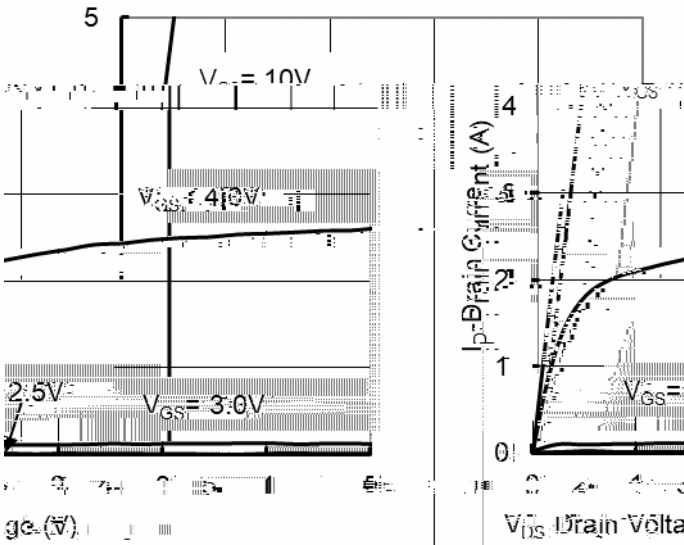

Figure 1. Output Characteristics

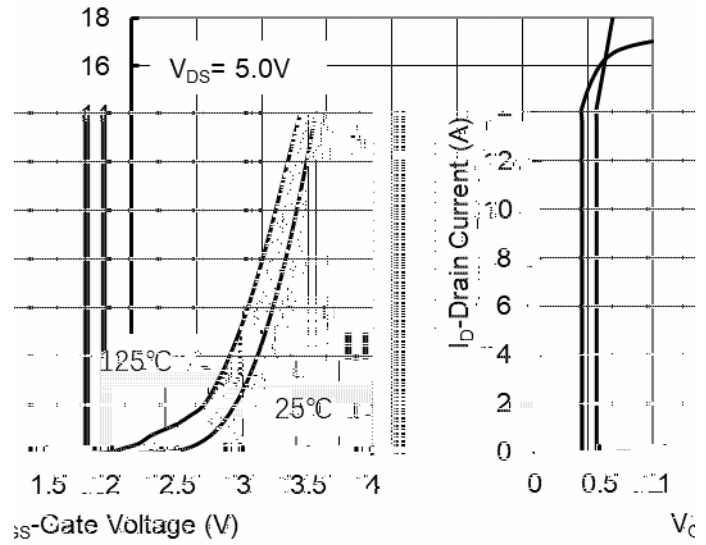

Figure 2. Transfer Characteristics

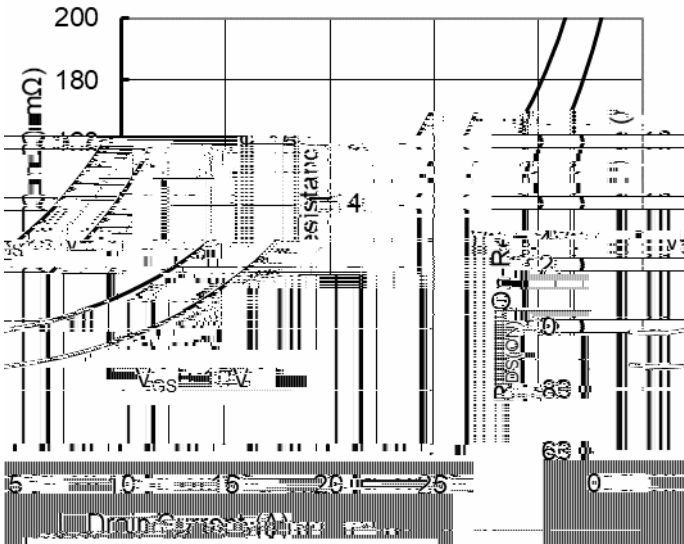

Figure 3. On-Resistance vs. Drain Current and Gate Voltage

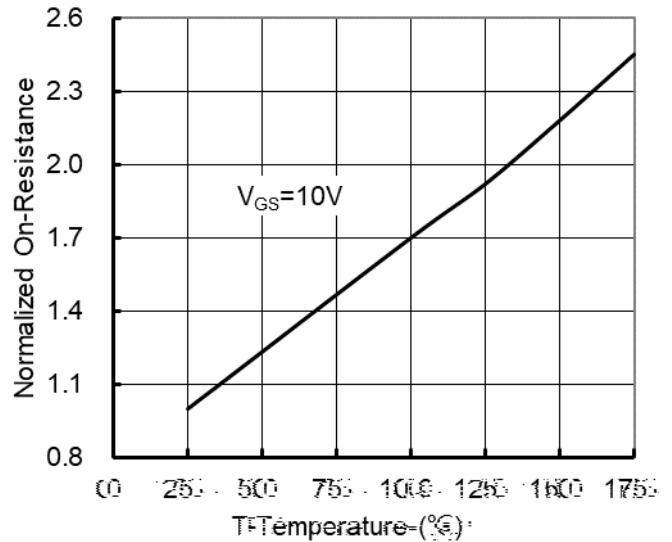

Figure 4. On-Resistance vs. Junction Temperature

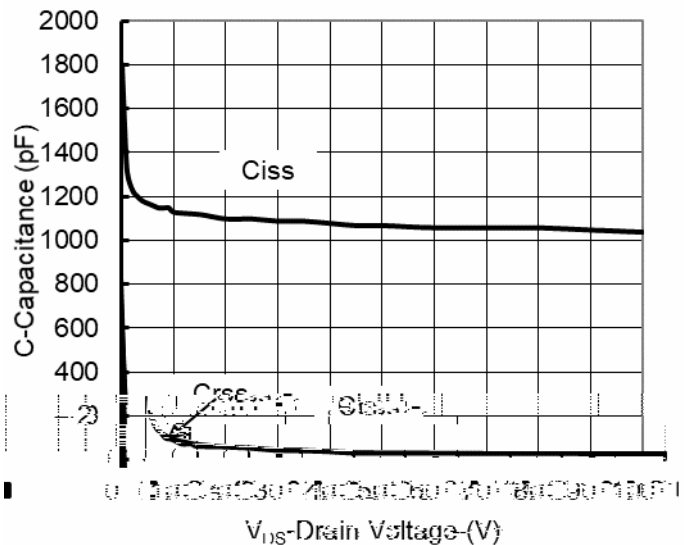

Figure 5. Capacitance Characteristics

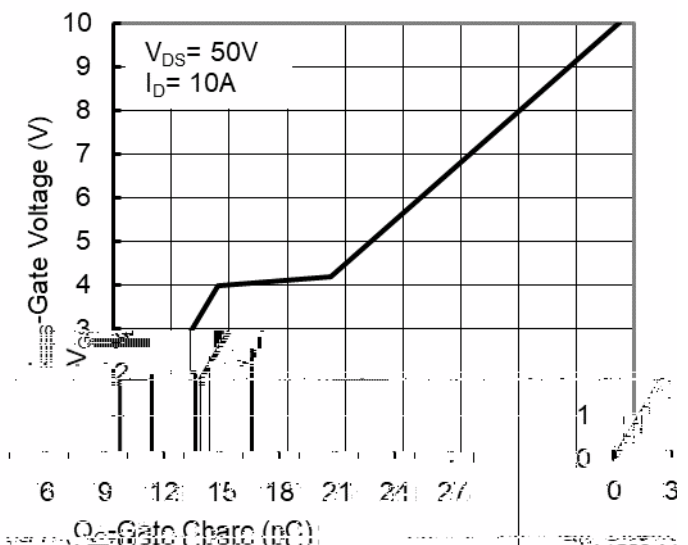
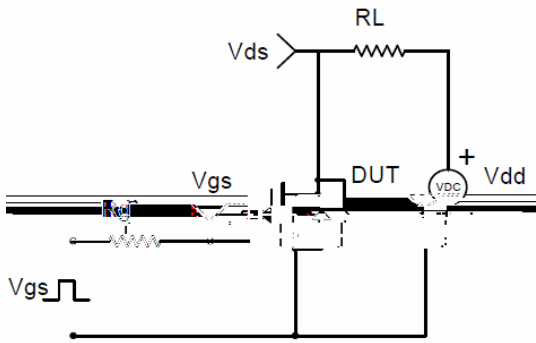
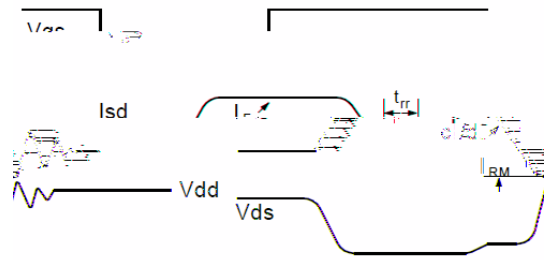
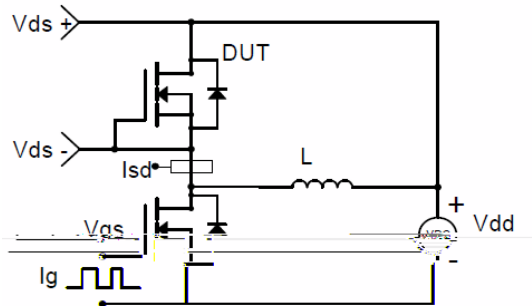

Figure 6. Gate Charge



Resistive Switching Test Circuit & Waveforms



Diode Recovery Test Circuit & Waveforms

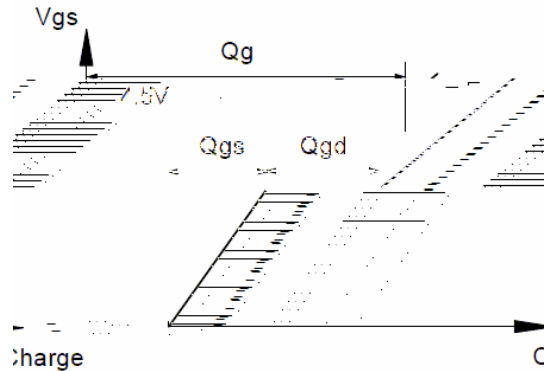
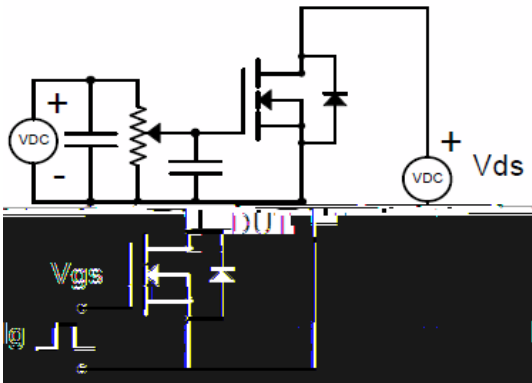

Gate Charge Test Circuit & Waveform

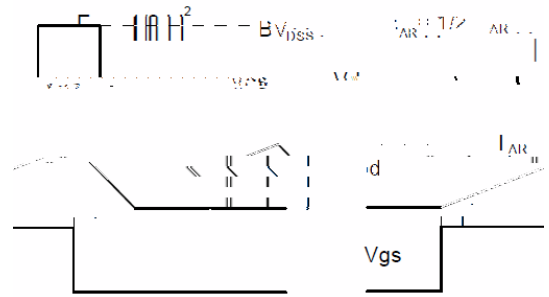
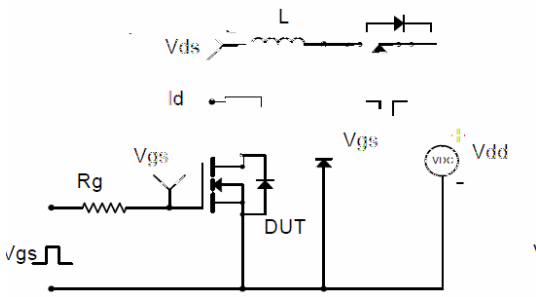

Unclamped Inductive Switching (UIS) Test Circuit & Waveforms



Disclaimer

The information presented in this document is for reference only. Yangzhou Yangjie Electronic Technology Co., Ltd. reserves the right to make changes without notice for the specification of the products displayed herein to improve reliability, function or design or otherwise.

The product listed herein is designed to be used with ordinary electronic equipment or devices, and not designed to be used with equipment or devices which require high level of reliability and the malfunction of which would directly endanger human life (such as medical instruments, transportation equipment, aerospace machinery, nuclear-reactor controllers, fuel controllers and other safety devices), Yangjie or anyone on its behalf, assumes no responsibility or liability for any damages resulting from such improper use of sale.

This publication supersedes & replaces all information previously supplied. For additional information, please visit our website [http:// www.21yangjie.com](http://www.21yangjie.com) , or consult your nearest Yangjie's sales office for further assistance.